

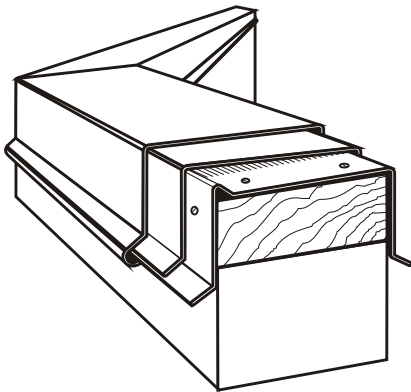

# PRODUCT DATA

## POWERTRIM®

PERIMETER SYSTEMS



- OUTSTANDING PERFORMANCE
- FACTORY ENGINEERED QUALITY
- CUSTOM FABRICATED TO JOB SPECS
- ALLOWS FOR THERMAL MOVEMENT
- EASE OF INSTALLATION
- NO EXPOSED FASTENERS
- ECONOMICALLY PRICED

*NOTE: this is a certifiable product.  
Performance Tested per ANSI/SPRI ES-1-98*

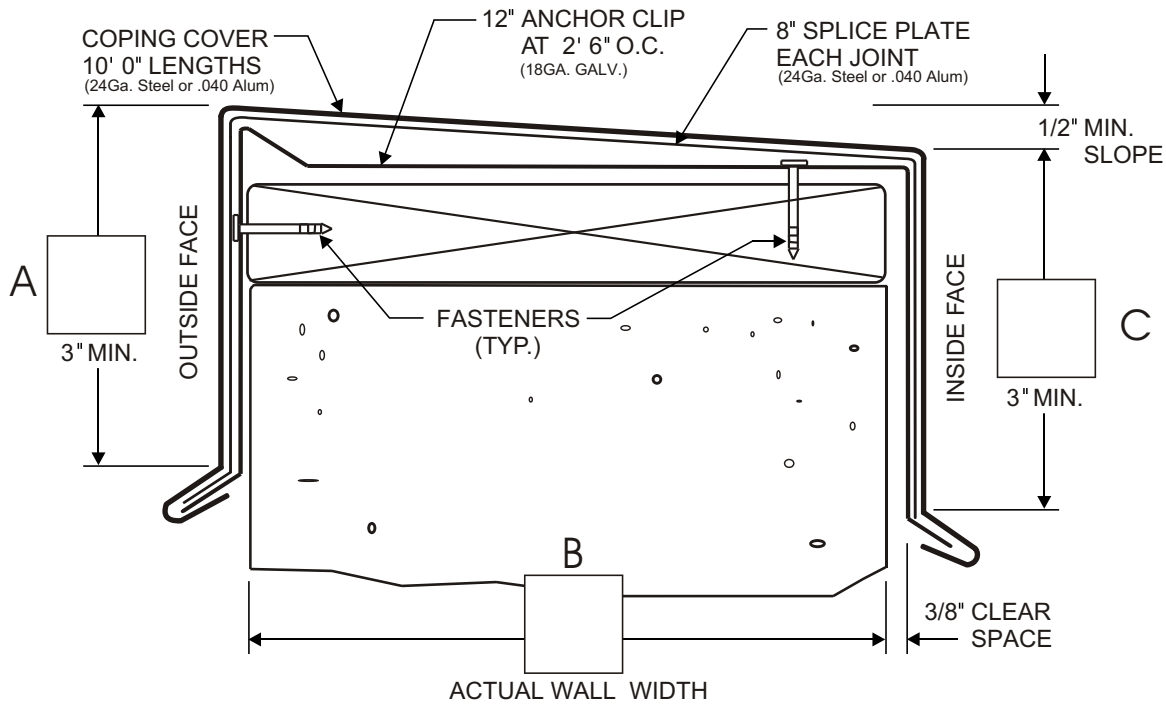

*NOTE: Concealed splice plates must be field caulked to prevent water entry.*

### SPECIFICATIONS

All material including coping, splice plate and anchor clips shall be manufactured by C&J Metal Products, Inc. Long Beach, CA. The coping shall snap to the anchor clip without the use of exposed fasteners.

### MATERIAL

**A. COPING** shall be .040 aluminum or 24GA galvanized steel, mill finish.

**B. SPLICE PLATE** shall be .040 aluminum or 24GA galvanized steel and finished to match coping. Splice plates are 8" long and shall be placed at each adjoining end.

**C. ANCHOR PLATE** shall be 18GA galvanized steel. Anchor to wall with appropriate fasteners for substrate at 2'6" on center.

**D. FINISHES AVAILABLE** - Mill finish aluminum, Mill galvanized steel, Factory bonderized steel, Factory baked enamel, and pre-painted PVDF fluoropolymer in standard colors.

12-06

**C & J METAL PRODUCTS INC**  
Serving the Building Industry Since 1946

6925 DOWNEY AVENUE LONG BEACH CA 90805  
800-500-8660 • 562-634-3101 • 562-634-8823FAX  
INTERNET: [www.CJMetals.com](http://www.CJMetals.com)



# Installation Instructions **POWERTRIM** COPING SYSTEMS

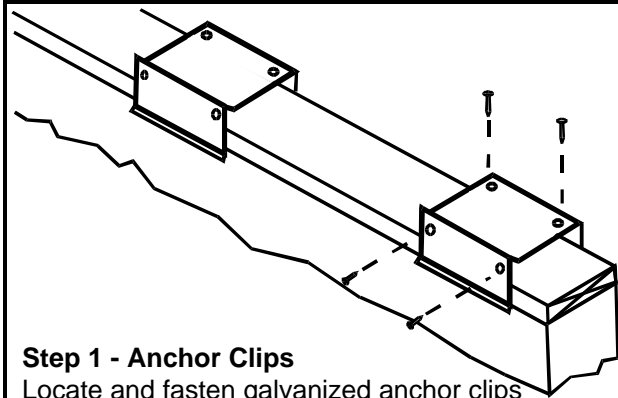

### Step 1 - Anchor Clips

Locate and fasten galvanized anchor clips to wall at 2'6" centers with appropriate fasteners for substrate.

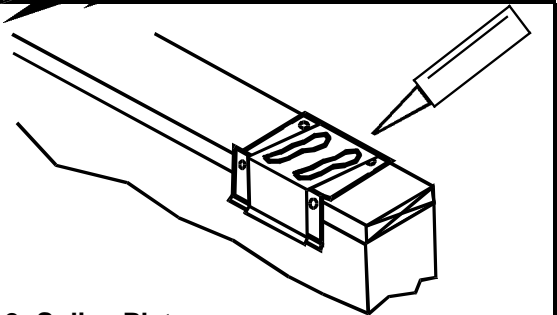

### Step 2- Splice Plates

Place splice plate onto anchor clips at splice joints, 10' -10'0" on center. Do not fasten splice plate to anchor clip. Sealant ( by others ) to be field applied to top of each splice plate as shown.

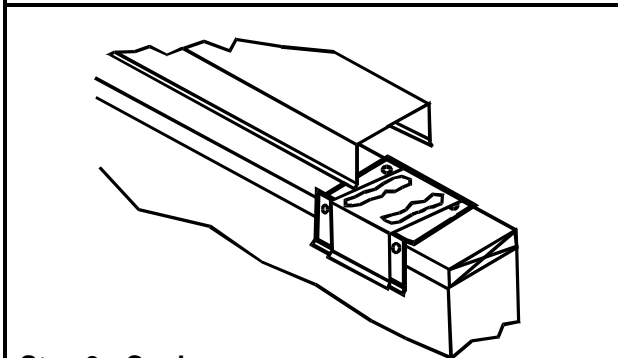

### Step 3 - Coping

Install coping by pushing coping down until it engages. Field crimp inside face of the coping drip at each anchor clip, 2'6" O.C.

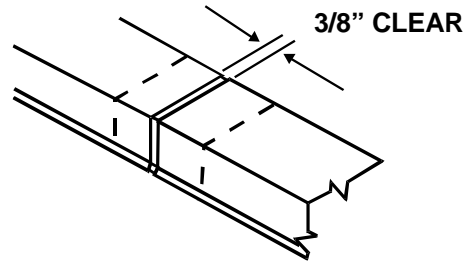

### Step 4 - Completion

Continue installing coping with a 3/8" space at splice joints to allow for thermal expansion. Field cut where necessary using fine tooth hacksaw or snips. **NOTE:** remove protective film if present.

### TYPICAL INSTALLATION

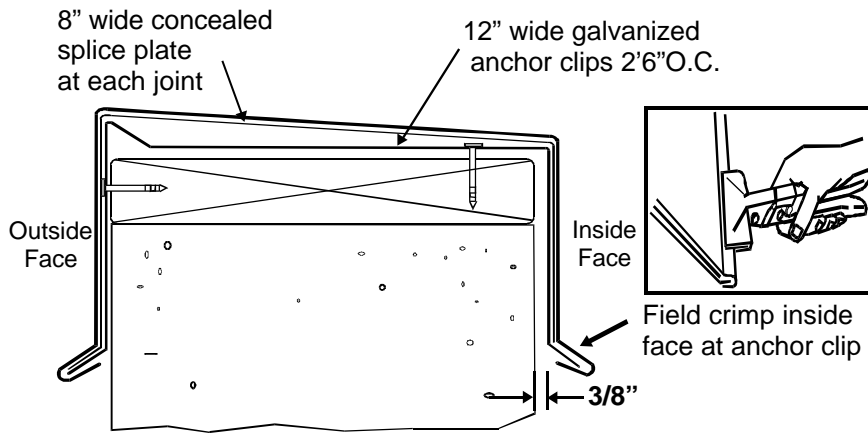

### FACTORY FABRICATED ACCESSORIES AVAILABLE

- END CAPS
- OUTSIDE MITERS
- INSIDE MITERS
- PILASTER COVERS
- T' MITERS



## SPECIFICATIONS AND INSTALLATION INSTRUCTIONS

## PRODUCT DATA

# POWERTRIM®

PERIMETER SYSTEMS

### DESCRIPTION

- A. Furnish and install the Powertrim Coping System as manufactured by C & J Metal Products, in strict accordance with manufacturer's printed instructions.
- B. Metal work other than the Powertrim Coping System is not covered by C & J Metal Products for any applicable warranties. Related metal work must be installed so as not to interfere with the performance of the Powertrim Coping System.

### QUALITY ASSURANCE

- A. Powertrim Coping System in standard sizes has been tested for pull-off in accordance with the current edition of ANSI/SPRI ES 1-98 "Wind Design Standard for Edge Systems used with Low Slope Roofing Systems".
- B. Installing contractor shall certify to C & J Metal Products that the Powertrim Coping System has been installed per manufacturer's printed details and specifications.

### SUBMITTALS

- A. Prior to the start of installation, the installing contractor shall submit to C & J Metal Products approval details showing size and width of the coping to be installed, including the type of metal.

### DELIVERY & PRECAUTIONS

- A. All Powertrim Coping materials shall be stored in a clean, dry location prior to installation.
- B. Materials provided with strippable protective plastic films should have film removed prior to installation. Such film-coated products shall not be exposed to sunlight for more than 30 minutes without removing film.

### WARRANTY

- A. Powertrim Coping Systems, when installed in accordance with manufacturer's written instructions, shall be free of defects in material and workmanship for a period of five (5) years from date of shipment.
- B. Product liability is limited to the repair

or replacement of manufacturer's furnished materials only. If, after inspection, the manufacturer agrees that materials supplied by them are defective, the manufacturer shall, at their option, repair or replace them. No other warranties either expressed or implied are applicable unless so stated in writing.

### INSTALLATION

- A. **SUBSTRATE PREPARATION:** The substrate should be flat and level from front to back. Shim areas not level. Wood nailers should be pressure treated wood secured by corrosion resistant anchor bolts countersunk into the wood nailer with nuts and washers. Anchor bolts should be of sufficient size and spacing to resist the design load and a minimum 200psf vertical load. For wood nailers wider than 6", bolts should be staggered to avoid splitting the wood. A fastener should be located approximately 4" and minimum 3" from each end of the wood. Fasteners should be staggered, spaced at a maximum 12 inches on centers, and should penetrate the wood sufficiently to achieve design pullout resistance. When embedded in masonry, anchor bolts as defined above should be bent 90 degrees at the base or have heads designed to prevent rotation and slipping out.
- B. **FASTENERS:** Factory pre-punched hold-down anchor clips shall be secured to substrate nailer mechanically with four #10x1 1/2 hex head screws or with optional barbed, annular ring shank nail of equal or greater pullout resistance. Fasten two screws at horizontal (top) side and two screws at vertical (front) face and anchor clip. Where adequate substrate nailer allows, place (2) vertical screws at holes closest to bottom edge of anchor cleat for maximum wind uplift resistance.
- C. **ANCHOR AND CORNER SUPPORTS:** Start at corners first. Locate and fasten galvanized anchor and corner support clips to nailer. Place splice plates onto anchor clips at all joints. Install miter

sections first by pressing downward over clips. Field crimp rear drip over back portion of anchor clips.

- D. **COPING SECTIONS:** Locate and install anchor clips to nailer at 2' 6" centers. Position end clips to allow for next section to share anchor. Position splice plates onto clips at all joint sections. Hook outside face of coping over drip and anchor clip and rotate into place. Press downward until snap lock occurs. Field crimp rear drip over back portion of all anchor clips. Provide 3/8" spacing at each joint to allow for thermal movement.

### CLEANUP:

- A. Remove and properly dispose of all foreign materials and debris from work area. Be sure no dissimilar metal or other materials are left on coping system.
- B. Wipe off all handprints, smudges and other superficial stains that were a result of the installation.
- C. Remove protective film immediately after installation where applicable.

### MAINTENANCE:

- A. No periodic maintenance is required, except in cases where certain finishes may require maintenance appropriate to the type of finish applied.

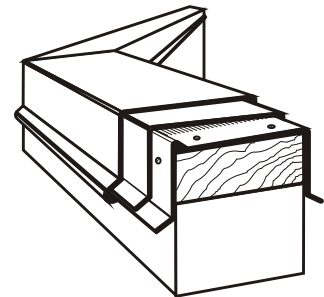

12-06